

# Extracting Second-Order Topographic Surface Features From Range Data

Robert B. Fisher

Dept. of Artificial Intelligence, University of Edinburgh  
5 Forrest Hill, Edinburgh EH1 2QL, Scotland, United Kingdom  
email: rbf@uk.ac.edinburgh.edai

---

*Second-order volumetric features (e.g. ridges, dents, bumps, etc) were previously defined to extend the SMS object modeling system. Here, we show that one can extract surface features from range data that can be described in this vocabulary of second-order features. The process is based on a classification of regions found by an approach based on local surface shape, and has a natural scale structure. Algorithms and results are given.*

---

## 1 Introduction

There has been considerable emphasis on range data interpretation in recent years. Most of the emphasis of this work has been on surface patch extraction, of which Besl's work<sup>1</sup> is an excellent example. The main motivations for surface patch extraction were three-fold:

1. large amounts of image data could be represented by compact surface patch descriptions,
2. results from differential geometry provided a sound basis for unique classification of local surface points, which could then be grouped according to their classifications and
3. much subsequent image interpretation, such as object recognition, needs to proceed using symbolic representations (i.e. compact, discrete, sparse and information rich).

Surface patches are not the only symbolic representations that can be extracted from range data, and this paper introduces second-order surface features. These features correspond to classes of shapes that also lie within human experience. The positive (extruding) features are: bump, spike, ridge and fin and the negative (intruding) features are: dent, hole, groove and slot (described further in Section 2). They are called "second-order" in two senses: (1) they are often smaller features that add detail to the surface, rather than specify the overall shape, and (2) they denote more specific, higher-level shapes.

We previously defined second-order volumetric features<sup>2</sup> for use in the SMS (Suggestive Modeling System) modeling system<sup>3</sup>. They can also be considered surface features, because they represent variations of the detail of the main volume, which are manifested as changes to the surface shape.

Each of the features are defined with respect to a local reference frame, and can thus be used as part of a model-independent scene description, containing surface patches, volumetric groupings and second-order volumetric features. Hence, the second-order surface features add additional detail to the topographic surface description<sup>4</sup>.

Scale is a factor in the question of what is a feature: a small spherical patch on a larger spherical patch can be considered as a pair of surface patches, or as a bump on a spherical patch, or as simply a bit of noise on a larger bump. While there is no well-agreed understanding of scale at present, we also show that the feature extraction algorithms have a natural scale behavior.

## 2 SMS and Second-Order Volumetric Features

SMS<sup>3</sup> is a modeling system designed for representing the salient visual characteristics of objects, as needed by an object recognition system<sup>5</sup> that primarily receives three-dimensional image evidence. SMS represents both viewpoint independent structural and viewpoint dependent observable structures and relationships. The primitive structural elements include points, space curves, surface patches and volumes. Complete objects are defined by a subcomponent hierarchy listing the feature and the reference frame transformation mapping the feature's coordinate system to that of the object.

The main volumetric primitives are the STICK, the PLATE and the BLOB<sup>6</sup>, which are designed for representing 1, 2 and 3 dimensions of extension. That is, a STICK represents elongated structures, the PLATE represents flattish structures and the BLOB represents more compact structures, having similar dimensions. Second-order features<sup>2</sup> were added to the first-order volumetric

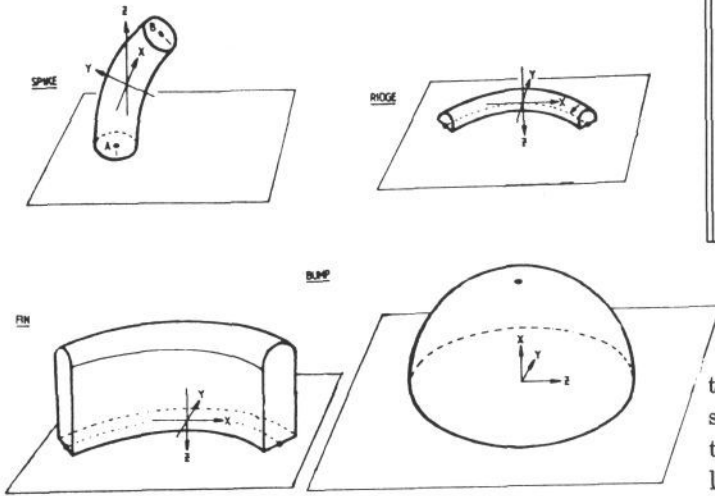

Figure 1: Positive Second-Order Features

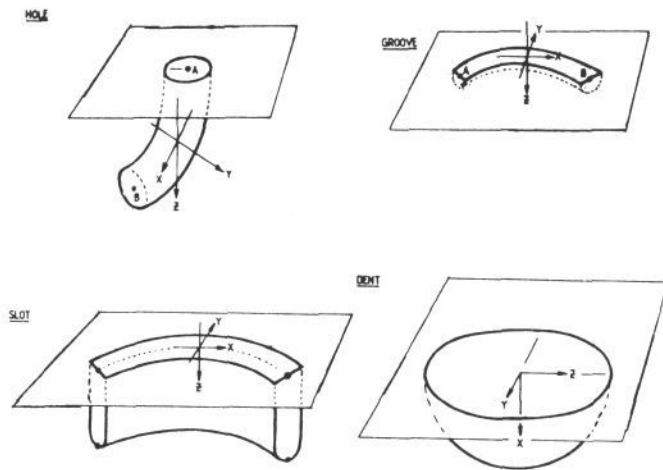

Figure 2: Negative Second-Order Features

primitives, to represent many obvious visual details, such as small intruding features, like holes, and small extruding features, such as bumps.

The second-order volumetric features are classified according to their having one, two or three primary directions of extension, and are positive or negative according to whether they protrude from or extend into the surface. The first one dimensional positive feature (Figure 1) is the SPIKE, which sticks out from a volume and possibly bends. The second one dimensional positive feature is the RIDGE, which lies on the surface of a volume. The two dimensional positive feature is the FIN, which represents something like a RIDGE, but extends substantially out of the object. The three dimensional positive feature is the BUMP, which represents a small hemi-ellipsoidal extrusion from a volume.

The first one dimensional negative feature (Figure 2) is

<sign>	<length>	<depth>	Classification
ABOVE	DEEP	LONG	FIN
ABOVE	DEEP	SHORT	SPIKE
ABOVE	SHALLOW	LONG	RIDGE
ABOVE	SHALLOW	SHORT	BUMP
BELOW	DEEP	LONG	SLOT
BELOW	DEEP	SHORT	HOLE
BELOW	SHALLOW	LONG	GROOVE
BELOW	SHALLOW	SHORT	DENT

Table 1: Principles of Feature Classification

the HOLE (dual of the SPIKE positive feature), which sticks into a volume. The second one dimensional negative feature is the GROOVE (dual of the RIDGE), which lies on the surface of a volume. The two dimensional negative feature is the SLOT (dual of the FIN), which is intended to represent something like a GROOVE, but which extends substantially into the object. The three dimensional negative feature is the DENT (dual of the BUMP), which represents a small hemi-ellipsoidal intrusion into a volume.

Some of the shape feature representation and ideas have been based on Kyprianou<sup>7</sup>, whose work attempted to deduce the more global structure of a surface feature from a local boundary (surface, edge and vertex) description, such as the existence of a protrusion from a set of connected planes.

### 3 Extracting The Features

We wish to find and classify surface regions that are different from the surrounding surface, which is assumed to be part of the "first-order" surface – surface features that might be extracted as patches by more traditional range data segmentation algorithms. The features are also assumed to be small, and thus describable as a whole, instead of being large enough to be described as a collection of distinct surface patches. Hence, finding the features is a difficult problem, because it requires a global understanding to decide which features should be described by the surface or second-order method.

The decision can also be dependent on the requirements of the later processing stages, and any intrinsic or extrinsic scale considerations. As we are not specifying these factors in this paper, we therefore do not strenuously limit the size of a second-order feature here.

The most basic properties of the second-order features are: (1) they protrude from or intrude into the surrounding surface and (2) they are isolated (i.e. are surrounded by non-feature uniform surface). These properties are exploited to locally classify (e.g.) protruding pixels, and then group them to form regions.

To reduce noise and suppress small features, a smoothing process precedes the region finding. Iteratively smoothing and repeating the segmentation produces a scale hierarchy, wherein new features appear and smaller features blend into the background.

Finally, the segmented image regions are classified into the taxonomy given in Section 2.

### 3.1 Preprocessing

To remove data defects and reduce minor data variations, several preprocessing stages occur:

1. "conservative smoothing" to remove outstanding data values,
2. expand and shrink to fill pixels with no value (due to deep holes or shadowed regions) and
3. two iterations of the smoothing convolution described in the next section.

### 3.2 Surface Smoothing

The surface data at each new scale level was smoothed using two iterations of a repeated-averaging (convolution) smoothing with the following kernel:

1	2	1
2	4	2
1	2	1

This smoothing approximates a Gaussian smoothing, is fast, and can be repeated to produce scale-effects. (The smoothing is known to produce shape changes at object boundaries, but they can be controlled<sup>8</sup>. Such control was not used here for simplicity.)

### 3.3 Region Finding

Features are based on surface regions that protrude from or extend into the surface. The approach used here was based on a local least-square planar surface patch fit. If the central point was closer than the estimate based on the best-fit surface at that point, then the point was classified as positive, otherwise it was negative.

The best plane fit was estimated over a 3\*3 window locally. In this case, the least squares estimate for the center position (using all 3D values for the points) is the mean of the range values in the neighbourhood. Hence, the determination of the relative position of the central point is equivalent to looking at the sign of difference

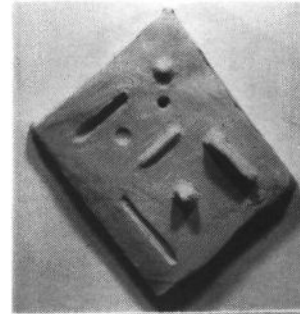

Figure 3: The Test Pieces

between the mean and the central point, which is equivalent to looking at the sign of the following convolution (applied to the smoothed data):

-1	-1	-1
-1	8	-1
-1	-1	-1

The pixels have their signs classified and are then grouped, if:

- are 4-connected (N/S/E/W),
- have the same sign and
- are not where the original background pixels were (the smoothing process diffuses the object into the background).

### 3.4 Region Rejection

When examining the results of the region location, it is obvious that not all regions should be features. Several tests are applied to eliminate unsuitable regions:

- **isolation test:** Regions adjacent to more than one region cannot be isolated by a surrounding region (and with no interior regions).
- **background test:** The background is eliminated.

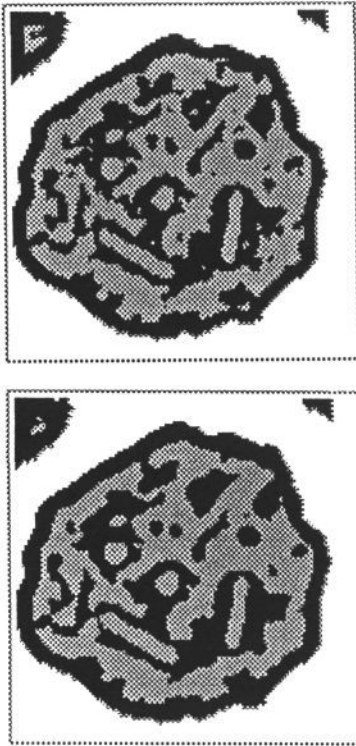

Figure 4: Shape Sign Classifications for Scales 1 & 2

- **background surround test:** Regions adjacent to the background cannot be features, as features must be surrounded by non-feature surface.
- **size test:** regions with small areas (less than 10 pixels) are eliminated, because the region finding method is sensitive at low levels of smoothing.
- **depth test:** regions with shallow depth (less than 1.5 mm) are eliminated, because the region finding method produces regions from shallow changes in depth.

Estimating feature depth is somewhat complicated, because neither the absolute, nor the local depth is desired, but the deviation of the feature from its surround, which might not be level. To account for this, the maximum depth is estimated along each raster scan that crosses the region:

1. finding pixels just before and after the region.
2. fitting a line through the two pixels.
3. finding the maximum deviation of the region pixels from this line.

### 3.5 Feature Classification

Regions are classified into features based on their sign, length and depth. These properties are estimated by:

- **<sign>** - whether the feature is ABOVE or BELOW the surrounding surface.

- **<length>** - whether the feature is LONG or SHORT. This classification is based on a heuristic related to compactness:

$$compactness = \frac{perimeter^2}{4\pi \times area}$$

A feature is classified as LONG if its compactness (minimum value 1.0) exceeds a threshold (2.0).

- **<depth>** - whether the feature is DEEP or SHALLOW. This classification is based on comparing a heuristic width  $W$  with an estimated depth  $D$ : If  $D/W > 2$  then the feature is DEEP. The depth is obtained during the depth test described above, and the width is estimated by:

$$W = \frac{8area^{1.5}}{perimeter^2}$$

The feature classification algorithm is based on Table 1.

## 4 Experiments

Figure 3 shows intensity images of the test objects - sculpted blocks of plasticine clay, each with one planned instance of each second-order feature. Object 1 is roughly hill-shaped, with a number of surface irregularities, and sits flat beneath the scanner. Object 2 has a nearly flat surface, but was scanned with its rightmost edge raised about 20 degrees to illustrate how the classification is based on features intrinsic to the surface, not the image. The raw data (not shown) was obtained from a laser striper with approximately 0.5 mm depth resolution.

We applied the above processes to range data taken from these objects. Figure 4 shows typical region sign maps for scales 1 and 2 of the first test part (black shows negative regions, grey shows positive regions). Note the encroaching dark region (shape deformation) at the object edge (referred to in Section 3.2).

Figure 5 shows the extracted features for several consecutive scales of analysis, where positive features are white and negative features are black. The scales and classifications of the features are in Table 2. All features but 8 and 16 were deliberately placed on the object, and were intended to be one instance of each feature type.

Object 1 has all but one feature located (the last was a shallow groove near the left edge of the object). A large shallow region, classified as a GROOVE, appeared at scale 2, but then disappeared. All feature classifications were initially correct, but feature 3 (a HOLE) was reclassified as a DENT at higher smoothings.

Object 2 is reported for scales 2, 3 and 4, because it's nearly-flat surface shape introduced more ABOVE/BELOW transitions at finer scales. As before, all but one intended feature was found, a BUMP near



Feat	Sign	Intended	Class	Scales
1	+	Y	RIDGE	1,2
2	+	Y	BUMP	1,2,3
3	-	Y	HOLE	1
4	-	Y	SLOT	1,2,3
5	-	Y	DENT	1,2,3
6	+	Y	FIN	1,2,3
7	+	Y	SPIKE	1,2,3
8	-	N	GROOVE	2
9	-	Y	DENT	2,3
10	+	Y	FIN	2,3,4
11	+	Y	SPIKE	2,3,4
12	-	Y	GROOVE	2
13	-	Y	HOLE	2,3,4
14	-	Y	SLOT	2,3,4
15	-	Y	HOLE	2,3
16	-	N	HOLE	2,3,4
17	+	Y	RIDGE	3,4

Table 2: Classification of Features in Figure 5

the left edge, apparently lost because of interference with nearby features. This was also the apparent cause of the unexpected feature 16 formed from the hollow at the base of the BUMP. The intended DENT (13) was misclassified as a HOLE, but it is deep enough for this classification. The RIDGE (17) initially is linked to a shallow adjacent region on the surface, but additional smoothing reveals the true feature.

Note that, as smoothing increases, the features that remain are mainly the deliberately introduced ones.

Results on other test objects are broadly similar, except that less prominent features are not always detected, because smoothing blends them into the surrounding surface before the local noise is reduced. If several features are close to each other, smoothing effects can introduce unexpected regions and classifications.

## 5 Discussion

Three techniques for finding the regions were explored. The first partitioned the surface by the sign of the output of a Laplacian operator, based on the analogy of finding lighter or darker regions from traditional image processing. While the zero-crossings of the sign are more commonly used (to find edge-like features), the zero crossings form closed boundaries, generally surrounding regions that are closer (or further) than the surrounding image.

While this method produced decent results, it was felt that it did not take explicit account of the local 3D shape, such as on curved surfaces. Hence, a second method based on the sign of the mean curvature of the local surface neighbourhoods and a third method (described in Section 3.3) were tried.

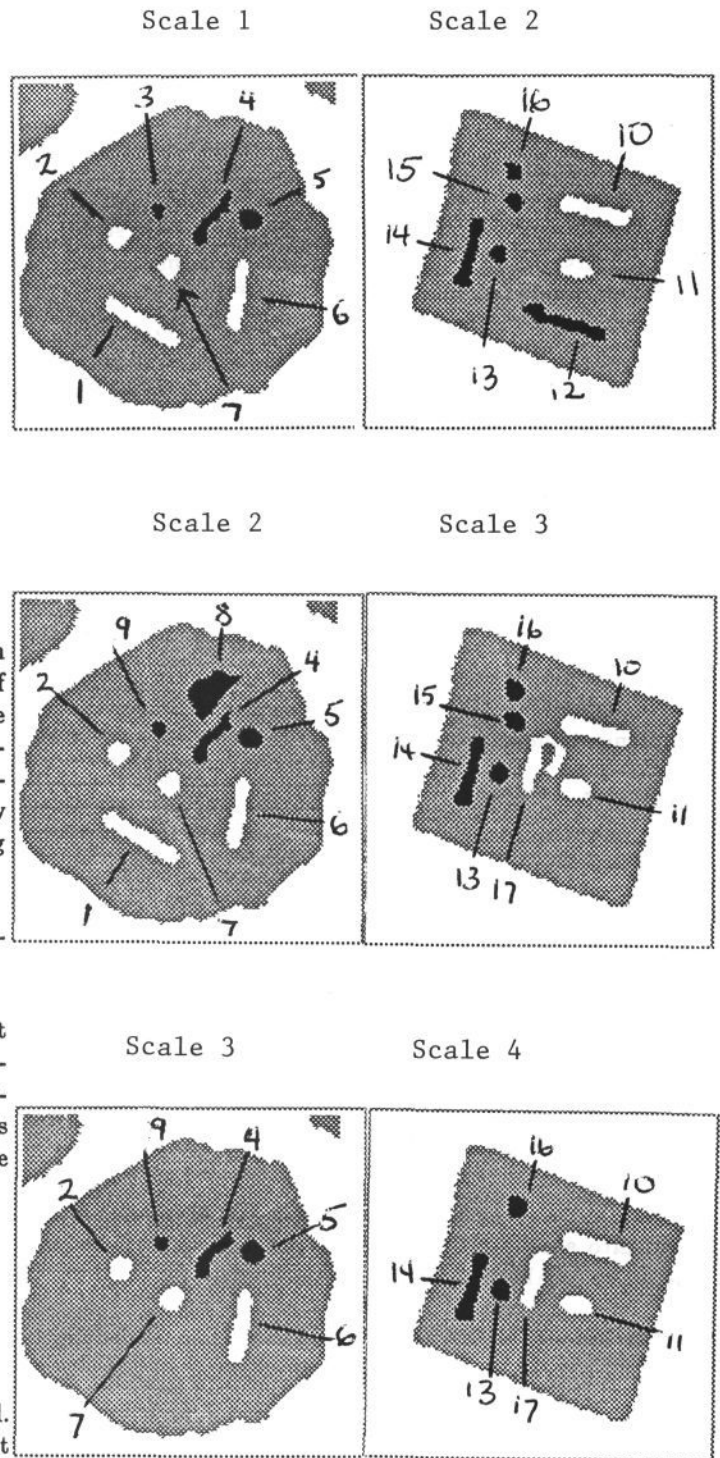

Figure 5: Extracted Features for Test Parts

The Laplacian and the least-squares methods (implemented as convolutions) produced similar results, mainly because the least-square convolution mask is identical to a mask often used for small Laplacian operators. The mean curvature approach also produced similar results, but was slower and tended to be less sensitive, particularly near curved surface features, where the Gaussian curvature was negative.

Because the range data is repeatedly smoothed, scale-based effects occur. While we have not made any systematic study of phenomena related to scale here, Witkin<sup>9</sup> and Yuille<sup>10</sup> explained how zero-crossings move and merge in (mainly) one dimension, when applied to Gaussian smoothed intensity data. As the features are extracted by a similar process, similar results are expected here. Cai<sup>11</sup> investigated the scale behavior of smoothed surfaces, but his features were surface patches defined using the mean and Gaussian curvature signs.

Noble<sup>12</sup> treated intensity images as 3D surfaces. Then, by applying morphological operators, surface features like edges, corners, ridges, etc. were extracted. Similar methods could be applied to range images, representing the corresponding 3D surfaces, resulting in features that complement those extracted here.

The interference between features that occurs as the smoothing scale increases is desired, because this removes minor features to reveal larger surrounding features. This can sometimes happen quickly, because, when features have gentle slopes at their edges, the features merge more quickly with their surrounding surface.

There is an element of figure/ground dilemma about feature classification. For example, one could classify the center of a torus as a hole, or the surrounding surface as a torus, or both. Here, we concentrate only on the second-order features.

One might detect surface patches first, and then assemble them into second-order features, but the small feature size make reliable patch extraction difficult.

The techniques described here should be extended for handling depth discontinuities around features, such as by not smoothing or classifying shapes across boundaries.

The second-order descriptive primitives introduce new descriptive features for scene representations. They extend the existing first-order scene descriptions (e.g. surface patches or volumes) to add the finer details that help distinguish identity. With the isolated and classified features, we can then extract their shape parameters and local reference frames, as defined in the SMS second-order feature primitives. On the other hand, the details of the feature may be less important than the presence of the feature, and its placement in the scene, relative to other scene features. With the more detailed scene descriptions, we can now more efficiently and discriminately recognize the objects in the scene.

## Acknowledgements

This work was funded by the University of Edinburgh. I'd like to thank H. Hughes and M. Trucco for advice.

## Bibliography

1. Besl, P. J., "Surfaces in Early Range Image Understanding", PhD Dissertation, Electrical Engineering and Computer Science Department (RSD-TR-10-86), University of Michigan, 1986.
2. Fisher, R. B., "Modeling Second-Order Volumetric Features", Proc. 3rd Alvey Vision Conference, pp 79-86, 1987.
3. Fisher, R. B., "SMS: A Suggestive Modeling System For Object Recognition", Image and Vision Computing, Vol 5, pp. 98-104, 1987.
4. Shapiro, L. G., Haralick, R. M., Pong, T. C., "The use of the Facet Model and the Topographic Primal Sketch in Image Analysis", in Brown (ed), *Advances in Computer Vision*, Vol 2, pp 1 - 46, Lawrence Erlbaum Associates, New Jersey, 1988.
5. Fisher, R. B., *From Surfaces to Objects: Computer Vision and Three Dimensional Scene Analysis*, John Wiley and Sons Ltd, Chichester, 1989.
6. Shapiro, L., Moriarty, J., Mulgaonkar, P., Haralick, R., "Sticks, Plates, And Blobs: A Three-Dimensional Object Representation For Scene Analysis", Proc. Amer. Assoc. for AI, pp 28-30, 1980.
7. Kyprianou, L. K., "Shape Classification in Computer-Aided Design", PhD thesis, Univ. of Cambridge Computer Lab, 1980.
8. Cai, L. D., "A 'Small Leakage' Model for Diffusion Smoothing of Image Data", Proc. 11th Int. Joint Conf. on Artificial Intelligence, pp1585-1590, 1989.
9. Witkin, A., "Scale-Space Filtering", Proc. 8th Int. Joint Conf. on AI, pp 1019-1021, Karlsruhe, 1983.
10. Yuille, A. L., Poggio, T., "Scaling and Fingerprint Theorems for Zero-Crossings", in Brown (ed), *Advances in Computer Vision*, Vol 2, pp 47-78, Lawrence Erlbaum Associates, New Jersey, 1988.
11. Cai, L. D., "Scale-Based Surface Understanding Using Diffusion Smoothing", forthcoming PhD thesis, Dept. of Artificial Intelligence, Univ. of Edinburgh, 1990.
12. Noble, J. A., "Morphological Feature Detection", Proc. 4th Alvey Vision Conf., pp 203-209, 1988.